



Information sheet

(Supplement to Technical Regulations, chapter 4.4.3)

Glass in stand construction and design inside trade fair halls

 This technical note has been jointly agreed upon the 9 German major fair companies:

Deutsche Messe AG Hannover
KölnMesse GmbH
Landesmesse Stuttgart GmbH
Leipziger Messe GmbH
Messe Berlin GmbH
Messe Düsseldorf GmbH
Messe Frankfurt Venue GmbH
Messe München GmbH
NürnbergMesse GmbH

These notes give the technical specifications, advices and requirements in reference to item /TG/ → 4.4.3 for glass structures in stand construction / design which are to be erected inside the trade fair and event halls of Messe Düsseldorf GmbH.

Düsseldorf, August 2018

CONTENTS

	PAGE
1 SCOPE OF APPLICABILITY	2
2 DEFINITIONS AND EXPLANATIONS	2
2.1 Types of supports	2
2.2 Types of glass and other thermoplastic materials	2
2.3 Design calculation standards	3
2.4 Material properties of glass products	4
3 CONSTRUCTIONS AND LOAD IMPACTS	5
3.1 Vertical glazing, not intended to prevent falling	5
3.2 Vertical glazing intended to prevent falls	5
3.3 Horizontal glazing	7
4 APPROVAL PROCEDURES	9
4.1 Basics	9
4.2 Installation clearance for a specific case	9
5 NOTES ON CONSTRUCTION AND DESIGN CALCULATION	10
6 EXAMPLES OF VERTICAL GLAZING (BARRIERS) DESIGNED TO PREVENT FALLS	11
6.1 Category B	11
6.2 Category C1 (Railing infills)	11
6.3 Balustrade with strong horizontal bars	14
7 CONSTRUCTION ENGINEERING REGULATIONS, GENERALLY ACCEPTED OF ENGINEERING AND REFERENCES	15
8 ABBREVIATIONS	15
9 KEYWORD INDEX	16
10 SPREADSHEETS A – D	17



Information sheet

(Supplement to Technical Regulations, chapter 4.4.3)

Glass in stand construction and design inside trade fair halls

1 SCOPE OF APPLICABILITY

This information sheet discusses the regulations concerning the use of glass in stand construction and design **inside trade fair or event halls**. It does not apply to stand construction and design outside trade fair halls.

Designing, dimension calculations and assembly of glass components for use inside trade fair halls require that the design, planning and assembly personnel / firms involved are adequately qualified for glass construction projects.

Glass structures which have received general construction approval (including European Technical Approval ETA) may be used in all cases in trade fair halls in accordance with the wording of the approval. This information sheet does not impose restrictions on the use of such structures.

2 DEFINITIONS AND EXPLANATIONS

2.1 Types of supports

All glass structures as follow can be divided into 2 different types of support:

→ Glazing secured by linear supports:

Secured by linear supports on at least two opposite edges over the full length of each edge of the glass plate.

→ Glazing secured at individual points:

Anchored through drilled holes or by a clamping system.

2.2 Types of glass and other thermoplastic materials

Types of glass granted statutory construction approval in Building Regulation:

→ Float glass (polished plate glass – PPG) as specified in DIN EN 572-9:

Also called flat or plate glass. It is characterised by relatively low ultimate flexural strength, and when destroyed, it fragments into large sharp-edged shards. Its use as single sheet glazing in trade fair construction is prohibited. If used in LSG, it is permitted in trade-fair construction.

→ Tempered safety glass (TSG) as specified in DIN 12150-2:

TSG is a fully thermally pre-stressed type of glass. It has internal residual stress characteristics: core tensile stress and surface compression stress. It has high ultimate flexural strength and when broken, it shatters into crumb-like fragments. Where TSG is referred to in this information sheet, TSG made of float glass is always meant.

→ Laminated safety glass (LSG):

LSG consists of at least two sheets of PPG, TSG or HSG glass. The individual thicknesses of these are not permitted to differ from each other by a factor of more than 1.5. The sheets of glass are laminated together by intermediate film layers (PVB or SGP films). If a sheet is broken, then the film prevents the fragments from being scattered, thus providing residual load-bearing capacities and reducing the risk of injury from cuts.

→ Heat-strengthened glass (HSG) as specified in DIN EN 1863-1 or with other general approvals by building authorities (German: Allgemeine bauaufsichtliche Zulassung – abZ):

HSG is a type of glass that is only partially thermally pre-stressed. Its ultimate flexural strength is lower than that of TSG (tempered safety glass). When broken, HSG fragments into shards which are larger than those of broken TSG. Therefore LSG sheets made of HSG have higher residual load-bearing capacities than LSG sheets made of TSG. HSG laminated with PVB film is included in Building Regulation. A general construction approval by building authorities (German: Allgemeine bauaufsichtliche Zulassung – abZ) for the SGP film is required for HSG laminated with SGP.

For all kinds of transparent, thermoplastic materials (like acrylic glass) no statutory construction approval has been granted and no recognised technical regulations / standards are available for such materials.

Out of these reasons

→ Acrylic glass (PMMA) under the brand names Plexiglas® and Perspex®, for example

→ Polycarbonat (PC) products: e.g. Makrolon®

→ Polyethylenterephthalat-Glycol (PET-G)

may only be used for non-load-bearing, decorative infill components. If such decorative infill components also used for overhead or ceiling covers think about their critical fire behavior of burning droplets.



Information sheet

(Supplement to Technical Regulations, chapter 4.4.3)

Glass in stand construction and design inside trade fair halls

2.3 Design calculation standards

The static strength proof calculations for glass components can be carried out in accordance with the following design calculation concept and structural design standards in the currently valid version:

DIN 18008 (parts 1 – 5) – Glass in Building - Design and construction rules

Part 1: Terms and general bases

Part 2: Linearly supported glazings → only in German version (available)

Part 3: Point-mounted glazing

Part 4: Additional requirement for fall-protection glazing

Part 5: Additional requirement for walk-in glazing

Table 1: Design concept

Design concept	Load factor concept
Proof concept	$\sigma_k * \gamma_f < f_k * k_c * k_{mod} / \gamma_M$
Determination of action effects and stresses	at ULS (GTZ)
Deformation checks	at SLS (GZG)
Designation of forces /stresses in the serviceability limit state SLS (forces due to characteristic loads, without γ_f)	SLS (GZG) after the number or index k after formula symbol e.g. supporting force = 12 kN (SLS) or $F_k = 12$ kN
Designation of forces /stresses in the ultimate limit state ULS (forces due to characteristic loads, multiplied by γ_f)	GZG (SLS) hinter der Zahl oder Index d am Formelzeichen supporting force = 16 kN (ULS) or $F_d = 16$ kN
Designation of the limit stress	f_k
Dimension calculation rules, dimension calculation standards	DIN 18008-1 [12] DIN 18008-2 [13] DIN 18008-3 [14] DIN 18008-4 [15] DIN 18008-5 [16]
Standards applying to loads and actions	this information sheet and DIN EN 1991 1 1 and DIN EN 1991 1 1/NA: (2010-12)
Normal load factors γ_f for permanent loads (e.g. dead loads)	1.35
Normal load factors for variable loads and actions (e.g. dynamic pressure, imposed loads, cross-bar pressures)	1.5
Duration of loads typically encountered at trade fairs for k_{mod} taken from DIN 18008-1, Table 6.	Own weight: permanent ($k_{mod} = 0.25$) Working loads: medium ($k_{mod} = 0.4$) Horizontal substitute load: short ($k_{mod} = 0.7$) Cross-bar pressure: short ($k_{mod} = 0.7$)

On the basis of said construction regulations and the design concept contained therein, and depending on the intended purpose, **all** glass constructions must be in the form of

- vertical glazing – possibly serving as barriers
- overhead glazing,
- glazing capable of supporting persons.

Their stability must be verifiable and the glass construction must be installed according to the applicable regulations. For static load calculations, the load factor concept shall be used as a basis. Supporting forces transmitted by glass components must always be stated for the ULS (GZT) so that the loads of the connected force-transmitting components of concrete, steel or wood can be calculated using the load-factor concept without transmission errors.

Advice for use of **wire glass**:

Wire glass is allowed only for existing components, if it is calculated / approved in accordance to the formerly technical standards right in time of the first-installation and by clearance of Messe Berlin.



Information sheet

(Supplement to Technical Regulations, chapter 4.4.3)

Glass in stand construction and design inside trade fair halls

2.4 Material properties of glass products

Glass products have a bulk density of 25 kN/m³, a thermal expansion coefficient of 8.4·10⁻⁶/K and their Young's modulus is 70.000 N/mm². For structural design calculations the design calculation values of the resistance R_d listed in Table 2 must be observed.

Table 2: Normal material properties for design calculation concept of load factors

Property	Floatglas (not printed, not sand-blasted)	HSG (not printed, not sand-blasted)	HSG (bedruckt / enamel coated)	TSG (not printed, not sand-blasted)	TSG (bedruckt, enamel coated)
Normal limit stress f _k as spec. in DIN EN 572-1, DIN EN 1863-1 or abZ, DIN EN 12150-1	45 N/mm ²	70 N/mm ²	45 N/mm ²	120 N/mm ²	90 N/mm ²
Design coefficient k _c normal	1.8	1	1	1	1
k _{VSG} for laminated safety glass	1,1	1.1	1.1	1.1	1.1
k _{Kante} for calculating the effect of glass edges	0.8	1	1	1	1
Material factor γ _M	1.8	1.5	1.5	1.5	1.5
Modification factor for calculating the effect of load durations k _{mod}	permanently: 0.25 medium term: 0.4 shortly: 0.7				
Rated value of the resistance to stress failure R _d	$R_d = k_{mod} * k_c * k_{VSG} * k_{Kante} * f_k / \gamma_M$	$R_d = k_c * k_{VSG} * k_{Kante} * f_k / \gamma_M$	$R_d = k_c * k_{VSG} * k_{Kante} * f_k / \gamma_M$	$R_d = k_c * k_{VSG} * k_{Kante} * f_k / \gamma_M$	$R_d = k_c * k_{VSG} * k_{Kante} * f_k / \gamma_M$

The intermediate films in LSG shall be made of PVB (Polyvinylbutyral) or SGP (SentryGlas® plus out of Ionoplast). Films made of PVB must have a tear strength of at least 20 N/mm².

SGP films shall have general approval by building authorities (including European Technical Approval ETA) and shall be processed in accordance with this approval.



Information sheet

(Supplement to Technical Regulations, chapter 4.4.3)

Glass in stand construction and design inside trade fair halls

3 CONSTRUCTIONS AND LOAD IMPACTS

3.1 Vertical glazing, not intended to prevent falling

3.1.1 Vertical glazing of a height $h \leq 4$ m above hall floor level

Neither static proof of structural characteristics in accordance with the regulations specified in item → 2.3 is required, nor is it necessary to submit documentation of testing. In this case the exhibitor alone is responsible for ensuring that the construction/design is technically safe for general use and that it meets current and accepted technical standards. Item 10 → Table A provides an overview of the types of structural designs that are possible.

- Either TSG or LSG must be used.
- The glass sheets may be secured by linear supports or at individual points.
- Glass walls tilting at an angle of more than 10° from the vertical are considered to be overhead glazing for which the provisions of item → 3.3 shall apply.
- Additional measures, e. g. provision of static proof calculations similar to those described in → 3.1.2, may be required to ensure protection of neighbouring walkways, or to be able to bear the loads of persons leaning against or bumping into the glass.

3.1.2 Vertical glazing of a height $h > 4$ m above hall floor level

Vertical glazing not intended to prevent falling and whose uppermost edges are higher than 4 metres above hall floor level does not require **Installation clearance for a specific case** (→ 4.2) provided that the type of glass used, structural design details and the type of supports securing the glass comply with the regulations specified in → 2.3.

In addition, the following provisions shall be observed:

- Verified*) structural calculations or structural calculations suitable for verification and the corresponding construction plans must be submitted.

*) Stability documents (including the examination report) are verified only if they have been examined in accordance with the respective state building regulations by an officially certified testing engineer or authorised building stability expert.

- In addition to the load of its own weight, the material must be capable of resisting horizontal forces, like pressure corresponding to at least $h_1 = 0.125$ kN/m² for visible surfaces of up to 4 m above hall floor level and at least $h_2 = 0.063$ kN/m² for visible surfaces at more than 4 m above hall floor level.
- Wherever there is a high risk of impact, e. g. where there is a descending ramp leading towards the glazing, additional measures are required.
- Proof of structural characteristics is not required if the area of each single-sheets is less than 1.6 sqm. and TSG with a thickness of at least 4 mm is used, and the sheet(s) is(are) held on four sides by linear supports.

Glazing secured at individual points may be used without further proof documentation if:

- general construction approval (abZ) has already been granted for the combination of point-mounting method and glass type and thickness, or
- the design specifications, and the dimensions and thickness of the glass as stated in DIN 18008-3, DIN 18008-4 or item 10 → Table B are adhered to.

DIN 18008-3 / -4 and Table B are referred to above because the fall-prevention glazing barriers described in these references are of course also suitable for glass panels not explicitly intended to prevent falls.

Installation clearance for a specific case is required for all other designs.

If the use TSG glazing is planned, a **heat soak** test certificate for **TSG-H** must be submitted.

Item 10 → Table A provides an overview of possible designs and the necessary proofs.

3.2 Vertical glazing intended to prevent falls

In all three of the following **categories: A, B and C**, static load proof calculations for the glass and the supporting structures as well as proof of the load-bearing capacity under impact-like conditions are required.

The static structural design calculations for the glass and the supporting structure shall be based on an assumed cross-bar pressure load and as an additional load case, a horizontal assumed surface load of $h_1 = 0.125$ kN/m² for all visible surfaces at up to 4 m above the hall floor level and of $h_2 = 0.063$ kN/m² for surfaces located at more than 4 m above hall floor level.

The load-bearing capacity of the structure under impact action can be verified as follows:

- a pendulum impact test in accordance with DIN 18008-4 is used, or
- the relevant design specifications, glass dimensions and thicknesses as stated in 10 → Table B of this information sheet are adhered to, or
- by providing proof calculations in accordance with the rules described in → 2.3.

Item 10 → Table B contains an overview of possible designs and the proofs required. All structural design details (including flexing/sag and glass insertion/clamping depths) shall be modelled in accordance with the rules described in → 2.3.

Experimental pendulum impact tests must be carried out by one of the test centres / institutes named in 10 → Table D well in advance of the fair and outside the trade fair halls.



Information sheet

(Supplement to Technical Regulations, chapter 4.4.3)

Glass in stand construction and design inside trade fair halls

- For category C 1 and C 2 type glazing, the use of TSG is allowed if the sheets are secured by linear supports on all sides. For all other types of supports and for category C 3, only LSG may be used unless other statutory construction approval exists.
- Item 10 → Table B contains an overview of possible designs and the proofs required.
- The pendulum impact test is not required if the relevant design specifications and the dimensions and thickness of the glass as stated in 10 → Table B or in DIN 18008-4 are adhered to.

Alternative measures / protection against glass breakage:

If the proof calculations for category C in accordance DIN 18008-4 are not submitted for accident-prevention (barrier) glazing, then the accident-prevention (barrier) attribute can be achieved by installing adequately sturdy knee-height cross-bars or tight stressed steel ropes of at least 5 mm diameter at a vertical spacing of not more than 35 cm and at an adequate distance in front of the glass infill sheets (see on item → 6.3).

Measures to protect against scattering glass splinters shall always be installed above and along the length of walkways, if this is not possible, LSG shall be used.

3.3 Horizontal glazing

3.3.1 Overhead glazing

Glass walls tilted at an angle of more than 10° from the vertical are considered to be overhead glazing. Item 10 → Table C contains an overview of possible designs and the proof documentation required.

Only the following glass products may be used:

- LSG made with float glass (PPG)
- LSG made of HSG,
- Wire glass (only for existing components (until effective span exceeding 0.7 m and the glass shall protrude into the supports by at least 15 mm).

In addition to submitting certification of load-bearing capacities, experimental proof of residual load-bearing capacities must be provided or, if this is not possible, a safety net must be hung under the glazing. If the structural design requirements of specified in DIN 18008-2 are met, proof of the residual load-bearing capacities is not required.

The design loads to be assumed are the sheet's own weight and a horizontal pressure corresponding to at least $h_1 = 0.125 \text{ kN/m}^2$ for visible surfaces of up to 4 m above hall floor level or $h_2 = 0.063 \text{ kN/m}^2$ for vertical visible surfaces at more than 4 m above hall floor level. The sheets must be secured in such a way as to properly safeguard against them slipping out of the mounts and forces which may lift them off the mounts.

The design dimensions of glass sheets mounted at individual points and HSG sheets shall either be calculated according to the rules outlined in → 2.3 or they must have general construction approval (abZ).

If, for cleaning purposes, overhead glazing periodically has to support human loads, then such additional loads must be taken into consideration and experimental proof of residual load-bearing capacities (in accordance to DIN 18008-5 [16]) must be provided. In such cases a special individual construction clearance is always required.

Further demands for overhead glazing are:

- LSG sheets with an effective span exceeding more than 1.20 m shall be supported on all sides.
- The overall thickness of the intermediate PVB- / SGP-films must be at least 0.76 mm. If a sheet is supported on all sides, only then a thickness of 0.38 mm is allowed under the condition that the effective span in the direction bearing the main load is not greater than 0.8 m.
- Cutting of recesses or notches in the glass sheets is not allowed.
- Only holes conforming to DIN 18008-3 are allowed.
- The maximum permissible sag shall not exceed 1/100 of the effective span between the closer supports of the sheet.

3.3.2 Glazing designed to support human loads

This kind of glazing is specifically intended to be subjected to persons walking over it, e. g. stairs, platforms, landings and cat-walks. The design and proof calculations shall take both dead loads (own weight) and the working loads into account. In addition, proof of impact resistance and residual load-bearing capacity shall be provided.

Proof of impact resistance and residual load-bearing capacities as a result of component tests must be submitted.

The requirements are specified in DIN 18008-5 [16]. For glazing mounted in linear supports at all four edges and an assumed working load of not more than **5.0 kN/m²** for design calculations, [→ Cat. C3 / T2 with DIN EN 1991-1-1/NA as freely accessible exhibition or meeting areas or as event areas and stairs] proof of impact resistance and residual load-bearing capacity is deemed to have been provided if the sheets conform to the dimensions listed in Table 3.



Information sheet

(Supplement to Technical Regulations, chapter 4.4.3)

Glass in stand construction and design inside trade fair halls

Table 3: Glazing mounted in linear supports at all four edges and intended to support human loads, with proven impact resistance and residual load-bearing capacity.

max. length [mm]	max. width [mm]	LSG structure [mm] (top / centre / bottom)	minimum supporting surface depth a [mm] → Pict. 2
1500	400	8 TVG ¹⁾ / 10 Float ¹⁾ / 10 Float	30
1500	750	8 TVG ¹⁾ / 12 Float ¹⁾ / 12 Float	30
1250	1250	8 TVG ¹⁾ / 10 TVG ¹⁾ / 10 TVG	35
1500	1500	8 TVG ¹⁾ / 12 TVG ¹⁾ / 12 TVG	35
2000	1400	8 TVG ¹⁾ / 15 Float ¹⁾ / 15 Float	35

¹⁾ = 1.52 mm PVB - / SPG - (Sentry glas® plus) intermediate film layer

Glazing designed to support human loads may be secured by linear supports or at individual points.

It must be made of LSG consisting of at least **three layers** of TSG and/or HSG/float glass.

From the point of view of impact resistance, the use of TSG or HSG for the top layer is recommended. This surface must possess non-slip characteristics in accordance with DIN 51097.

In order to achieve the required residual load-bearing capacity, the two lower layers will normally be made of float glass or HSG.

Pict. 3: Supporting surface depth a (German: Glaseinstand)

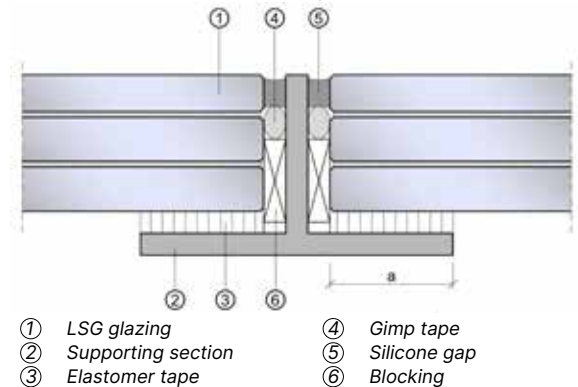

Glazing, mountings and supporting structure must be designed and their dimensions calculated to withstand the load of their own combined weight (dead load) as well as intended human (working) loads in accordance with the design calculation concept and all relevant and applicable standards [16] or → Table 4.

Table 4: Working loads / flexure limits for support human loads glazing

Design calculation concept	DIN 18008-5
Working surface load q _k depending on usage category in accordance to DIN EN 1991-1-1 or DIN EN 1991-1-1/NA	C1: 3.0 kN/m ² C3, T2: 5.0 kN/m ²
Point load Q _{kl} as an additional changing load parameter to be investigated	C1: 4.0 kN T2: 2.0 kN
Application area of point load	50 × 50 mm
Inclusion of top sheet in structural static calculations allowed	only for constant design situation and for temporary design situation
Proof calculation for situation with broken top sheet (i.e. only the two lower sheets still bear the load)	proof for an extraordinary design load calculation situation
Standards relating to the action of loads	DIN EN 1991-1-1 and DIN EN 1991-1-1 / NA
Max. sag / flexure [f] with 3 load-bearing sheets	l/ 200 (→ Pict. 4)
Max. sag / flexure [f] with 2 load-bearing sheets	l/ 100 (→ Pict. 4)

In the case of stairways the construction / design must guarantee sufficient distribution of loads. Stairs on stand structures inside exhibition halls shall always be classified with usage category T2

Pict. 4: Effective span exceeding [l] and flexure [f]

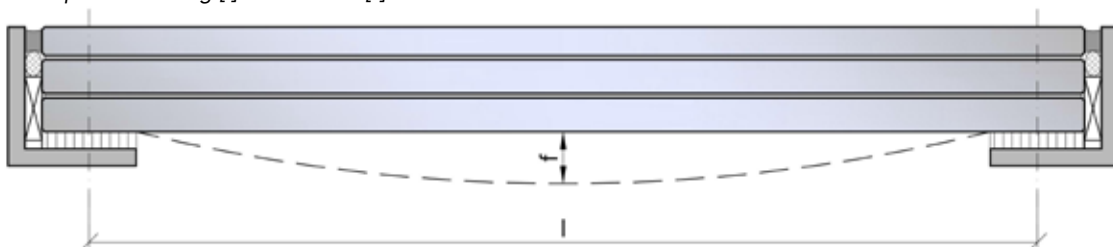



Information sheet

(Supplement to Technical Regulations, chapter 4.4.3)

Glass in stand construction and design inside trade fair halls

4 APPROVAL PROCEDURES

4.1 Basics

If a glass component and its glass products conform to the technical building regulations outlined in → 2.3 and to generally accepted technical principles, then it shall be sufficient to submit the verified structural calculations and the verified plans, following which construction approval will be granted. In addition, the construction work on site will be checked and the results subjected to an approval inspection.

If additional components are installed for which statutory construction approval, a statutory construction test report (abP) or type approval (abZ) are required, then these documents are to be submitted together with the structural calculations.

If a glass component or parts of this component do not conform to the construction engineering regulations and generally accepted technical principles outlined in → 2.3, and if no statutory construction approval or statutory construction test certificate can be produced, then an individual construction approval (Zustimmung im Einzelfall – ZiE) shall be required. An Installation Clearance for a Specific Case (CfS) may be granted by Messe Düsseldorf instead of the individual construction approval if glass is used only within the rules and limitations described in this information sheet.

4.2 Installation clearance for a specific case (CfS)

This clearance procedure is similar to the procedure for obtaining individual construction approval.

If an Installation Clearance for a Specific Case (CfS) has been granted once for a particular construction / design and type of usage, then the favourite German trade fair companies in question will accept this for an identical design serving an identical purpose. Nevertheless, a new application for construction work clearance and local inspection (TG → 4.2) shall be submitted for each repeated case. The test report, all certificates and approvals, design details, as well as glass dimensions and thicknesses must be submitted with the application.

Glass components requiring approval and which require type 3 proof documentation are listed in column 14 of 10 → Tables A, B and C.

Installation clearances for specific cases cannot be granted at short notice, as they require a considerable period of time for processing. Applications for these should therefore be submitted at least 6 weeks before the commencement of construction.

Prior to conducting component tests, it is advisable to contact Messe Düsseldorf in good time in order to coordinate procedures and intended testing methods. Normally, component testing requirements stipulate inclusion of parts of the glass component's actual substructure in order to simulate realistic loads.

The procedure for obtaining an **Installation Clearance for a Specific Case (CfS)** is as follows:

- The structural calculations and the required certificates confirming the identity of the product(s) (glass manufacturer / processing company's factory certificates) must be verified and checked by a publicly certified structural building surveyor and tester (in the field of steel, concrete and brick construction / engineering).
- The surveyor shall confirm that there are no objections with regard to the design's suitability for use. It is his responsibility to decide on the necessity of additional testing of materials, impact resistance and
- whether further proof of residual load-bearing capacities must be obtained. The test report must be submitted to Messe Düsseldorf along with the other application documents requesting construction work permit (construction permit) and subsequent monitoring of the stand construction work and stand clearance inspection.

Recommended institutes for testing components used in glass construction / design are mentioned in 10 → table D.



Information sheet

(Supplement to Technical Regulations, chapter 4.4.3)

Glass in stand construction and design inside trade fair halls

5 NOTES ON CONSTRUCTION AND DESIGN CALCULATION

Glass is a brittle material, any failure of which will occur spontaneously and without warning.

Glass is sensitive to blows with hard, pointed objects.

These properties lead to the following guideline notes:

- Proof calculations for the load-bearing capacity of structural glass not only take into consideration the unbroken glass but always include an investigation of the broken or partially broken glass (**proof of residual load-bearing capacity**).
- All support design must ensure that glass sheets are not subjected to pressure or stresses by the supports.
- Direct glass-to-glass contact and contact between glass and other hard materials (e.g. metal) shall be prevented at all times, whereby the effects of load and temperature fluctuations have to be taken into account.
- The minimum supporting depths of glass sheets ("glass insertion depth") on their respective support sections as well as the allowable sheet and supporting beam sections as specified in → 2.3 for the design calculation concept must be adhered to.
- After glazing has been installed, the markings identifying the individual type of glass sheet used (e.g. TSG, HSG) must be durable and legible at all times. In the case of LSG glazing, a section of the edge must be left free for inspection purposes (to check the number of glass sheets, thickness, interlayer films) until the construction has been approved. If required, a manufacturer's certificate shall be submitted as well.
- The edges of glass sheets must be finished or protected in such a way as to exclude any possibility of injury.
- In the case of TSG, HSG, or LSG glazing manufactured from sheets of TSG or HSG, subsequent reworking of the finished product such as cutting out sections or drilling holes is not possible.
- Sheets intended to bear human loads must have a durable non-slip surface finish.
- Load-bearing adhesive joints may only be used if a general construction approval (abZ) has been granted for the entire adhesive system (i.e. the glass, adhesive and metal combination), and under the condition that the joint is made exactly as described in the approval documents. The rules described in → 2.3 do not yet make allowance for applying more favourable assumptions of the joint effect of the intermediate film layers in LSG and therefore an **Installation Clearance for the Specific Case (CfS)** has to be applied for if these assumptions are used in calculations. Trade publications [18] contain information on suitable calculation assumptions to account for the joint effects in LSG. This may possibly be useful for LSG in which SGP is used.



Information sheet

(Supplement to Technical Regulations, chapter 4.4.3)

Glass in stand construction and design inside trade fair halls

6 EXAMPLES OF VERTICAL GLAZING (BARRIERS) DESIGNED TO PREVENT FALLS

All possible dimensions, types of glass, thicknesses and the necessary proof documents are summarised in 10 → Table B.

6.1 Category B (Clamped glass balustrade with continuous handrail, see on pict. 1)

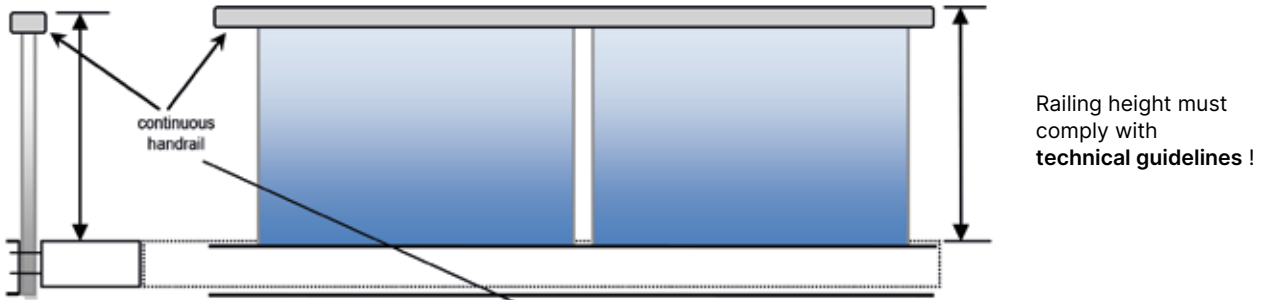

Note:

- If LSG made
 - of 10 mm TSG + 1,52 mm PVB/SGP + 10 mm TSG
 - of 10 mm HSG + 1,52 mm PVB/SGP + 10 mm HSG
- in the dimensions as stated in 10 → Table B is used, only static structural proof calculations are required.

As specified in DIN 18008-4, this also applies to parallelogram-shaped balustrades.

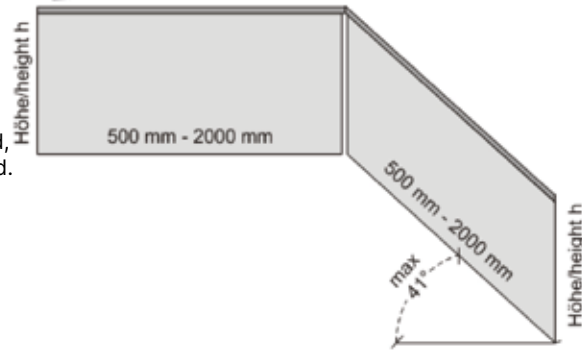

6.2 Category C1 (Railing infills)

6.2.1 Railing infills secured vertically on 2 sides

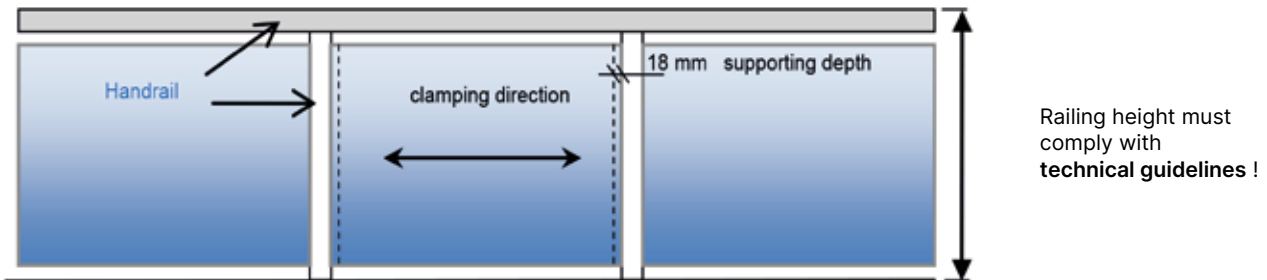

6.2.2 Railing infills secured horizontally on 2 sides

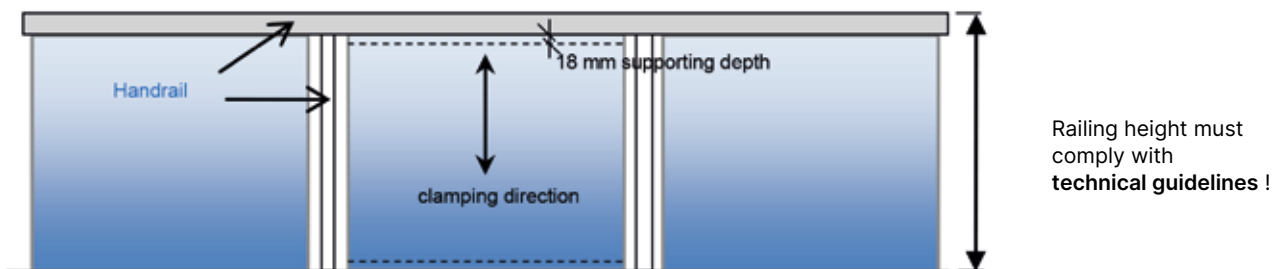



Information sheet

(Supplement to Technical Regulations, chapter 4.4.3)

Glass in stand construction and design inside trade fair halls

6.2.3 Railing infills secured on 4 sides

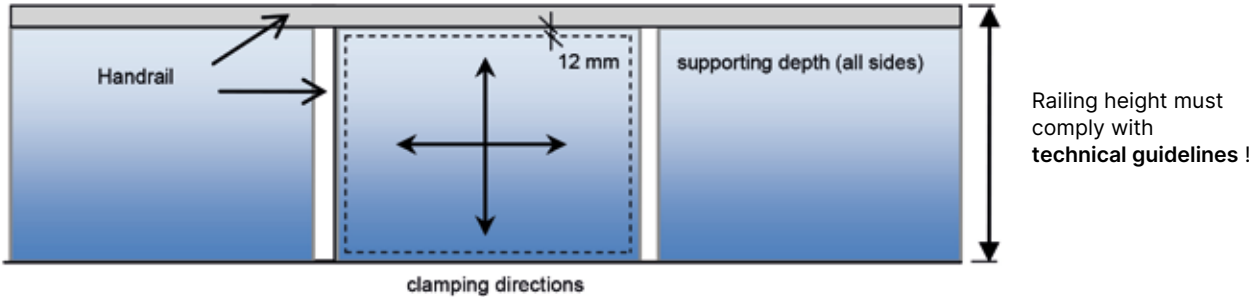

Note for all types before:

If the types of glass and the dimensions listed in 10 → Table B are used, only static structural proof calculations are required.

6.2.4 Infill glazing secured at individual points by means of drilled anchor points (design specifications in accordance with DIN 18008-3 / -4)

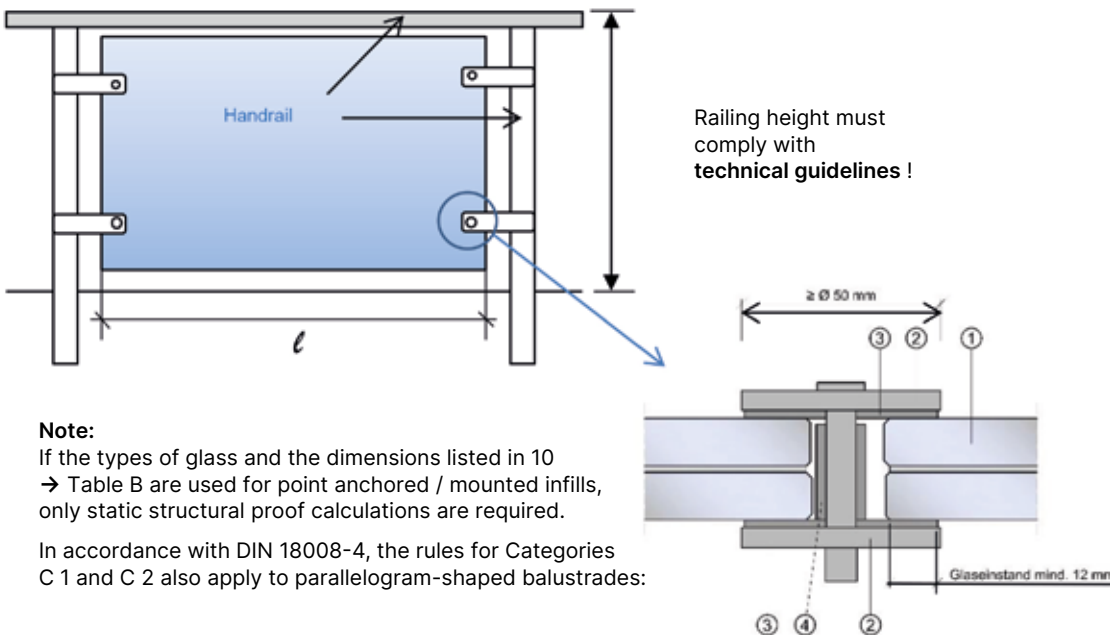

Note:

If the types of glass and the dimensions listed in 10 → Table B are used for point anchored / mounted infills, only static structural proof calculations are required.

In accordance with DIN 18008-4, the rules for Categories C 1 and C 2 also apply to parallelogram-shaped balustrades:

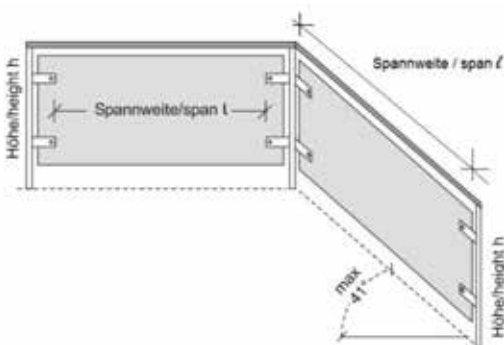

Pict. 5:
Circular plate (section)
for drilled anchor points

- ① LSG glazing
- ② Clamping retainer
- ③ Elastomer
- ④ Sleeve



Information sheet

(Supplement to Technical Regulations, chapter 4.4.3)

Glass in stand construction and design inside trade fair halls

6.2.5 Point mounting railing infills with lateral clamps and anti-slip grips

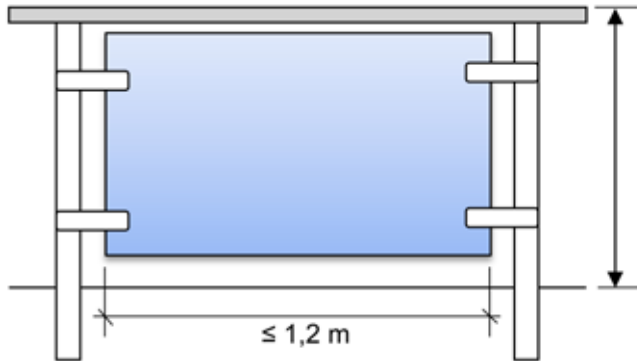

Railing height must comply with **technical guidelines !**

Note:

Designs that have a general construction approval (abZ) shall be used in accordance with. For all systems that have not been granted general construction approval, a pendulum impact test is required. Minimum requirement for LSG comprising:

- 6 mm ESG + 1.52 mm PVB + 6 mm ESG
- 6 mm TVG + 1.52 mm PVB + 6 mm TVG shall be used.

6.2.6 Point mounting railing infills with clamps at top and bottom

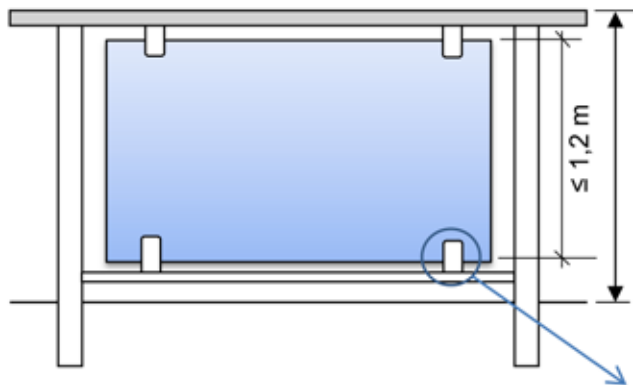

Railing height must comply with **technical guidelines !**

Note:

System designs that have a general construction approval (abZ) shall be used in accordance with the specifications in the approval documents.

For all systems that have not been granted general building approval, a pendulum impact test is required. Minimum requirement for LSG comprising:

- 6 mm TSG + 1.52 mm PVB + 6 mm TSG,
- 6 mm HSG + 1.52 mm PVB + 6 mm HSG shall be used.

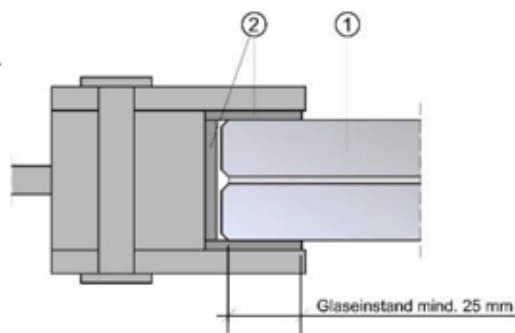

Pict. 6:
Terminal holder (section)

- ① LSG glazing
- ② Elastomer



Information sheet

(Supplement to Technical Regulations, chapter 4.4.3)

Glass in stand construction and design inside trade fair halls

6.3 Balustrade with strong horizontal bars

→ protection against falling is provided solely by sufficiently strong handrails and knee-height bars

Compensating measures:

If glazing can't be verified in accordance to category C (DIN 18008-4), the protection against falling had to be provided solely by sufficiently strong handrail and knee-height bars. Such knee-height bars are available also as tensed up steel ropes (min. \varnothing 5 mm). The spacing between horizontal bars in all cases should not exceed approx. **35 cm**.

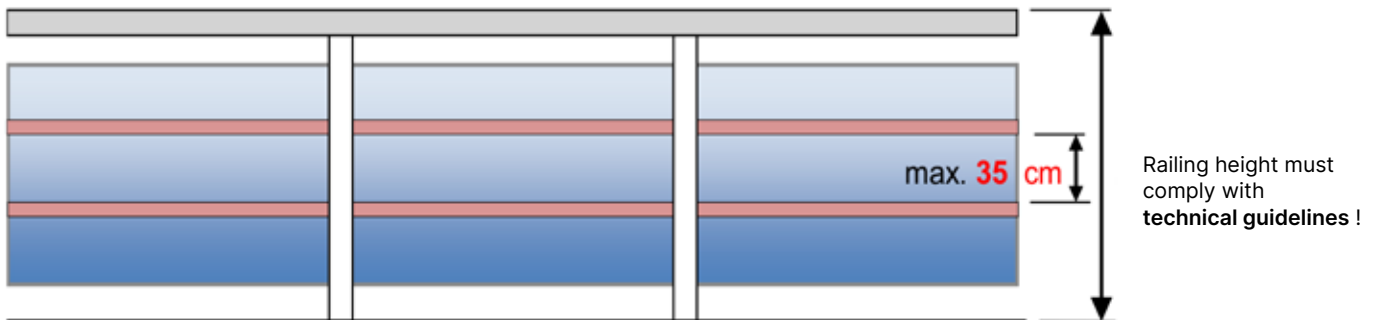

Note:

In the compensating case of strong horizontal bars the type of glass used shall be selected from → 10, Table A, glazing not intended to protect against falls. In order to prevent public visitors (especially children) from climbing over the balustrades, only vertical bars are permitted in front of glazing.



Information sheet

(Supplement to Technical Regulations, chapter 4.4.3)

Glass in stand construction and design inside trade fair halls

7 CONSTRUCTION ENGINEERING REGULATIONS, GENERALLY ACCEPTED OF ENGINEERING AND REFERENCES

- [1] *Wörner J.-D., Schneider J., Fink A.*: title "Glasbau: Grundlagen, Berechnung, Konstruktion", published by Springer-Verlag, Berlin Heidelberg; 2001
- [2] *Bucak, Ö.*: Glas im konstruktiven Ingenieurbau, in Stahlbau Kalender, published Ernst & Sohn Verlag für Architektur und technische Wissenschaften GmbH, Berlin, 1999
- [3] *Sedlacek S., Blank K., Laufs W., Güsgen J.*: title "Glas im Konstruktiven Ingenieurbau". (1. Aufl.) Ernst & Sohn Verlag für Architektur und technische Wissenschaften GmbH, Berlin, 1999
- [4] *Siebert G.*: title "Entwurf und Bemessung von tragenden Bauteilen aus Glas". Published by Ernst & Sohn Verlag für Architektur und technische Wissenschaften GmbH, Berlin, 2001
- [5] *Bucak, Ö.; Schuler, C.*: Glas im Konstruktiven Ingenieurbau, in Stahlbau Kalender. Published Ernst & Sohn Verlag für Architektur und technische Wissenschaften GmbH, Berlin, 2008
- [6] *Feldmann, M.; Kasper, R.*: Glasbau im europäischen Kontext, in Stahlbau Kalender. Published Ernst & Sohn Verlag für Architektur und technische Wissenschaften GmbH, Berlin, 2015
- [7] *Weller, B., Krampe, P., Reich, S.*: Glasbau-Praxis, Konstruktion und Bemessung, 3. Aufl., Band 1: Grundlagen, published Beuth Verlag GmbH Berlin, Wien Zürich 2013
- [8] *Weller, B., Engelmann, M., Nicklisch, F., Weimar, T.*: Glasbau-Praxis, Konstruktion und Bemessung, 3. Aufl, Band 2: Beispiele nach DIN 18008, published Beuth Verlag GmbH Berlin, Wien Zürich 2013
- [9] *Wörner, J.-D; Schneider J.*: Closing report on experiments and calculations to determine the dynamic stresses on glass as a result of a light impact, Fraunhofer IRB Verlag Stuttgart 2000, Booklet T 2935
- [10] *Völkel, G.E.; Rück R.*: Investigation into panes with linear support on 4 sides when subjected to impact, Fraunhofer IRB Verlag Stuttgart 2000, Booklet T 2915
- [11] *Weller, B., Nicklisch, F., Thieme, S. Weimar, T.*: Glasbau-Praxis in Beispielen, Konstruktion und Berechnung, Bauwerk-Verlag 2. Aufl. 2010
- [12] DIN 18008-1 (December 2010) Glass in Building – Design and construction rules – Part 1: Terms and general bases
- [13] DIN 18008-2 (December 2010) Glass in Building – Design and construction rules – Part 2: Linearly supported glazings
- [14] DIN 18008-3 (July 2013) Glass in Building – Design and construction rules – Part 3: Point fixed glazing
- [15] DIN 18008-4 (July 2013) Glass in Building – Design and construction rules – Part 4: Additional requirements for barrier glazing
- [16] DIN 18008-5 (July 2013) Glass in Building – Design and construction rules – Part 5: Additional requirements for walk-on glazing
- [17] *Kasper, R., Pieplow, K., Feldmann, M.*: Beispiele zur Bemessung von Glasbauteilen nach DIN 18008; published Ernst & Sohn Verlag für Architektur und technische Wissenschaften GmbH, Berlin, 2016
- [18] *Wellershof, F.*: Bemessungsschubmodule für Verbundglasscheiben, Stahlbau 76 (März 2007), H.3, pp. 177-188
- [19] Building rules list (see www.dibt.de)
- [20] ETA Ass.directive: Building components designed to prevent falls

8 ABBREVIATIONS

abZ	German: Allgemeine bauaufsichtliche Zulassung (general construction approval)
CfS	Installation Clearance for a Specific Case (German: Einbau-Freigabe im Einzelfall - FiE)
C1, C3	Categories for vertically acting working loads on floors of public meeting spaces in buildings as specified in DIN EN 1991-1-1 / NA
DIBt	Deutsches Institut für Bautechnik (German civil engineering institute)
ESG	German: Einscheiben-Sicherheitsglas (fully-tempered glass / toughened safety glass → TSG)
HSG	Heat-strengthened glass
LSG	Laminated safety glass
PPG	Polished plate glass (German: Spiegelglas → SPG)
PVB	polyvinyl butyral (intermediate film material for LSG)
SGP	SentryGlas® plus (intermediate film material for LSG)
SLS	Serviceability limit state
SPG	German: Spiegelglas (float glass or PPG)
T2	Category for vertically acting working loads on stairs / staircase landings for large traffic loads and escape staircases as specified in DIN EN 1991-1-1 / NA
TSG	Toughened safety glass
TVG	German: Teilvorgespanntes Glas (heat-strengthened glass → HSG)
ULS	Ultimate limit state
VSG	German: Verbund-Sicherheitsglas (laminated safety glass → LSG)
ZIE	German: Zustimmung im Einzelfall (individual construction approval)



Information sheet

(Supplement to Technical Regulations, chapter 4.4.3)

Glass in stand construction and design inside trade fair halls

9 KEYWORD INDEX

Abbreviations	15
acrylic glass, polycarbonate products,	
PET-G approval	2, 4, 5, 7, 9, 10, 13
balustrade infills	6
balustrades	6, 11, 12, 14
building surveyor	9
category A	6
category B	6, 11
cat-walks	7
clamps (terminal holder)	6, 13
combination of point-mounting method and	
glass type/thickness	5
component tests	7, 9
construction approval	2, 5, 7, 9, 10, 13
documents for application for design calculation concepts	9
effective span	7, 9
experimental proof	7
float glass	2, 7, 8
general approval by building authorities	4
general construction approval	2, 5, 7, 10, 13
glass wall	5, 6, 7
glazing	3, 5, 6, 7, 11
heat soak test certificate	5
HSG / heat-strengthened glass	2, 4, 6, 7, 8, 10, 11, 13
impact resistance	7, 8, 9
individual construction approval	9
infills	6, 11, 12, 13
Installation Clearance for a Specific Case (CfS)	9
LSG / laminated safety glass	2, 4, 5, 6, 7, 8, 10, 12, 13
landings	7
limit stress	3, 4
limit stress f_k	4
load factor	3, 4
material properties	4
overhead glazing	3, 5, 7
pendulum impact tests	6
PPG / polished plate glass	2, 7
pressure, horizontal	5, 7
rated value of the resistance to stress failure R_d	4
residual load-bearing capacities	2, 7, 9
safety net	7
Sag (deformation)	6, 7, 8
SLS / serviceability limit state	3
stairs	7, 8
supports / mounting, types	2, 5, 7, 8, 10
supporting surface depth	8, 12, 13
test report	9
TSG / tempered safety glass	2, 4, 5, 6, 7, 8, 10, 11, 13
type approval	9
types of supports	2, 7
ULS / ultimate limit state	3
vertical glazing	3, 5, 6, 11
wire glass	3, 7
working loads	
C1, C3, T2 nach DIN EN 1991-1-1/NA	3, 6, 7, 8, 15



Information sheet

(Supplement to Technical Regulations, chapter 4.4.3)

Glass in stand construction and design inside trade fair halls

Table B: Vertical glazing, intended to prevent falls (barrier glazing)

1	2	3	4	5	6	7	8	9	10	11	12	13	14	15					
Type	Character-istic	Structure type		Glass type	Allowed, yes/no	Glass thickness in mm	SGP / PVB film thickness	Width in mm		Height in mm		Min. glass insertion depth in mm	Type of proof required	Civil engi- neering rules					
		Structure	Sheet support					min	max	min	max								
Fail- prevention, barrier ($\Delta h > 1\text{ m}$)		Glass wall (cat. A as defined in DIN 18008-4)	Linear support on 2 sides	TSG	no. 2)		0,76						18	2, 4	DIN 18008-1/2/4				
				LSG 2 layers	yes														
			Linear support on 4 sides	TSG	no. 2)														
				LSG 2 layers	yes														
				TSG	no. 2)														
				LSG 2 layers	yes														
		Point supports	TSG	no. 2)															
			LSG 2 layers	yes															
		Balustrade / parapet clamped at the bottom, with handrail (cat. B as defined in DIN 18008-4)		Linear clamping at one edge	TSG	no. 2)													
					LSG 2 layers	yes													
					TSG	no. 2)													
					LSG 2 layers	yes													
TSG	no. 2)																		
LSG 2 layers	yes																		
Railing infill (cat. C 1 and C 2 as defined in DIN 18008-4)		Linear support at top and bottom	TSG	no. 2)															
			LSG 2 layers	yes															
			TSG	no. 2)															
			LSG 2 layers	yes															
			TSG	no. 2)															
			LSG 2 layers	yes															
Railing infill (only cat. C 1 as defined in DIN 18008-4)		Linear support at left and right	TSG	no. 2)															
			LSG 2 layers	yes															
			TSG	no. 2)															
			LSG 2 layers	yes															
			TSG	no. 2)															
			LSG 2 layers	yes															
Glass wall with load-bearing / protective handrail in front of it (cat. C 3 as defined in DIN 18008-4)		Linear support on 2 sides	TSG	no. 2)															
			LSG 2 layers	yes															
			TSG	no. 2)															
			LSG 2 layers	yes															
			TSG	no. 2)															
			LSG 2 layers	yes															
Kind of proof:		Point supports	TSG	no. 2)															
			LSG 2 layers	yes															
			TSG	no. 2)															
			LSG 2 layers	yes															
			TSG	no. 2)															
			LSG 2 layers	yes															

If a pendulum impact test, proof type "4", is not specified in column 14, then this advantage is subject to adherence to the limit values stated in columns 7 to 13. Structural designs not listed here will require an Installation Approval for the Specific Case.

2) In systems having a valid general statutory construction approval, LSG may be used in accordance with the text of the approval documents.

3) The distance between neighbouring point supports in x-direction and in y-direction, respectively.

4) Clamped on both faces by circular plates with diameter $\phi \geq 50\text{ mm}$, if spacing is greater than 1200 mm, plate diameter shall be $\phi \geq 70\text{ mm}$, see DIN 18008-3/4

The use of thermoplastics materials (acrylic glass) and wire glass is **not allowed** for vertical glazing intended to prevent falls (barrier glazing).

If the sheets are held in linear supports, LSG made of HSG and with the same specified thicknesses may be used instead of LSG made of float glass.



Information sheet

(Supplement to Technical Regulations, chapter 4.4.3)

Glass in stand construction and design inside trade fair halls

Table C: Horizontal glazing

1	2	3	4	5	6	7	8	9	10	11	12	13	14	15			
Type	Characteristic	Structure type		Glass type	Allowed, yes / no	Glass thickness in mm (top / centre / bottom) (1) = 1,52 mm PVB / SGP	SGP / PVB film thickness	Length in mm		Width in mm		Min. glass insertion depth in mm	Type of proof required	Civil engineering rules			
		Structure	Sheet support					min	max	min	max						
Overhead glazing angled at > 10° to the vertical(1)			Linear support on 2 sides	LSG 2 layers	no		0,76		1200 (4)				2 (5)	DIN 18008-1/2			
				Wire glass	yes				700 (4)					2	7)		
				LSG 3 layers	no												
				Wire glass	yes												
				LSG 2 layers	yes				0,76		700 (4)					2 (5)	DIN 18008-1/2
				Wire glass	yes											2	7)
				LSG 3 layers	no												
				Wire glass	yes				1,52							2, 3, 6 (6)	DIN 18008-1...3
				LSG 2 layers	no												
				Wire glass	yes										30	2 (5)	DIN 18008-1...5
Walkable glazing for supporting persons		Installed at height ≤ 20 cm	Linear support on 4 sides	LSG 2 layers	no												
				Wire glass	yes												
				LSG 3 layers	yes				1,52		1500		400				
				Wire glass	yes						1500		750				
				LSG 3 layers	yes				1,52		1250		1250			2	DIN 18008-1...5
				Wire glass	yes						1500		1500				
				LSG 3 layers	yes				1,52		2000		1400				
				Wire glass	yes											2 (5)	DIN 18008-1...5
				LSG 2 layers	no												
				Wire glass	yes											2 (5)	DIN 18008-1...5
Walkable glazing for supporting persons		Installed at height > 20 cm	Linear support on 2 sides	LSG 2 layers	no												
				Wire glass	yes												
				LSG 3 layers	yes												
				Wire glass	yes												
				LSG 2 layers	no												
				Wire glass	yes												
				LSG 3 layers	yes												
				Wire glass	yes												
				LSG 2 layers	no												
				Wire glass	yes												
Kind of proof:			Point supports	LSG 2 layers	no												
				Wire glass	yes												
				LSG 3 layers	yes												
				Wire glass	yes												
				LSG 2 layers	no												
				Wire glass	yes												
				LSG 3 layers	yes												
				Wire glass	yes												
				LSG 2 layers	no												
				Wire glass	yes												

1: No specific proof
 2: Verified static calculations
 3: Installation clearance for specific case
 4: Pendulum impact test
 5: Heat soak test
 6: Residual load-bearing cap. test
 7: Shock impact resistance test

3) Overhead glazing that has to be capable of supporting human loads to permit cleaning is subject to a special approval procedure.
 4) The data apply to the smaller distance between supports (support direction).
 5) If HSG which has not received general statutory construction approval (abZ) is used, an additional **Installation Approval for the Specific Case** is required.
 6) If glass type / support type combination systems which have been granted a general statutory construction approval (abZ) are used, the Installation Approval for the Specific Case is not required.
 7) Wire glass is allowed only for existing components, if it is calculated / approved in accordance to the formerly technical standards right in time of the first installation and by clearance of Messe Berlin.
 The use of thermoelastic materials (acrylic glass) for horizontal glazing is **not allowed**. However, exceptions may be possible if Messe Düsseldorf has no objections with regard to fire prevention/protection (burning droplets) and structural stability.



Information sheet

(Supplement to Technical Regulations, chapter 4.4.3)

Glass in stand construction and design inside trade fair halls

Table D: Recommended German institutes for testing components used in glass construction / design

<p>Technische Universität Dresden, Institut für Baukonstruktionen (Beyer-Bau)</p> <p>Prof. Dr.-Ing. Weller August-Bebel-Str. 30 01219 Dresden</p>	<p>MFPA Leipzig GmbH Hans-Weigel-Str. 2B 04319 Leipzig</p>	<p>TU Hamburg - Harburg Institut für Baustatik und Stahlbau</p> <p>Prof. Dr.-Ing. Starossek Denickestr. 7 21073 Hamburg</p>
<p>Leibnitz-Universität Hannover Institut für Massivbau</p> <p>Prof. Dr.-Ing. Marx Appelstr. 9a 30167 Hannover</p>	<p>Materialprüfanstalt für das Bauwesen Braunschweig Beethovenstr. 52 38106 Braunschweig</p>	<p>MPA Nordrhein-Westfalen Marsbruchstr.186 44287 Dortmund</p>
<p>RWT Aachen Lehrstuhl für Stahlbau</p> <p>Prof. Dr.-Ing. Feldmann Mies-van-der-Rohe-Str. 1 52074 Aachen</p>	<p>MPA Darmstadt Grafenstr. 2 64283 Darmstadt</p>	<p>TU Darmstadt Institut für Werkstoffe und Mechanik im Bauwesen</p> <p>Prof. Dr.-Ing. Wörner Franziska-Braun-Str. 3 64287 Darmstadt</p>
<p>FMPA Baden-Württemberg FB 2, Abt. 21, Referat 214 Pfaffenwaldring 4 70569 Stuttgart (Vaihingen)</p>	<p>Universität Karlsruhe Versuchsanstalt für Stahl, Holz und Steine</p> <p>Prof. Dr.-Ing. Ummenhofer Otto-Amman-Platz 1 76131 Karlsruhe</p>	<p>Friedmann & Kirchner Gesellschaft für Material- und Bauteilprüfung Große Ahlmühle 7 76865 Rohrbach</p>
<p>FH München Labor für Stahl- und Leichtmetallbau</p> <p>Prof. Dr.-Ing. Bucak Karlstr. 6 80333 München</p>	<p>TU München Lehrstuhl für Metallbau</p> <p>Prof. Dr.-Ing. Mensinger Arcisstr. 21 80333 München</p>	<p>Institut für Fenstertechnik e.V. Theodor-Grieti-Str. 7-9 83025 Rosenheim</p>