

Important Notes

2026

Technical supply

On the last exhibition day the supply of electricity, water and compressed air is stopped one hour after fair conclusion for safety reasons. If you require electricity for deconstruction purposes, please contact the technical services counter in the fair management or the electrician in the hall.

Technical installation/services – Forms "Stand walls/Paper hanging", "Electrical Installations Hall", "Stand lighting" and "Sanitary Installations/Compressed Air"

With the forms "Stand walls/Paper hanging", "Electrical Installations Hall", "Stand lighting" and "Sanitary Installations/Compressed Air" technical services can be ordered. A sketch with placement, should be attached to the order form, otherwise placing takes place at the discretion of the Messe Düsseldorf.

Noise level regulations

The use of acoustic advertising mediums will, if necessary, be controlled by an acoustics engineer. The resulting costs will then be passed on to the exhibitor.

Authorization for welding, cutting, and abrasive cutting

All work involving an open flame and/or sparks requires written authorization. This authorization contains information on the protective measures. The area must be protected against sparks and strong heat dissipation. Fire-fighting agents must be provided close by and produced upon request of an authorized representative of the Messe Düsseldorf. Once the work is complete, a responsible person must inspect the work areas to ensure that they do not pose a danger – e.g., through the presence of embers, smoke etc.

Orders

Reservations and orders can usually be made as soon as you have registered with OOS. They must be completed in full and must be submitted via OOS by the relevant dates, specified separately. If forms are submitted late, Messe Düsseldorf can give no guarantee that work will be completed properly or on time and/or may then be unable to perform the relevant work at all.

Questions to this subject

Technical Service

Tel.: +49 211 4560-500

eMail: tr-service@messe-duesseldorf.de



Fax +49 211 4560-8566

Messe Düsseldorf GmbH, Abt.: UT-SAS
Postfach 10 10 06, 40001 Düsseldorf, Germany

Phone +49 211 4560-500
tr-service@messe-duesseldorf.de

Questions?

Order Form

Stairs and Platforms

Please enter orders in the ground plan sketch sent to you with the approval documentation (can also be called up and processed in OOS online in the forms for technical performance items). Prices include material (rental), construction and dismantling. For incomplete documentations and all orders submitted less than 21 days before set-up time Messe Düsseldorf adds a surcharge of 35% on the fees.

Event
Hall/Stand number

B 10
GB
2026

Trade Fair Stand

Ident-Nr.	Amount ordered	All stand construction dimensions must be divisible by 0.5!	Unit	Rental price per unit in € plus VAT
Platform type A: stairs and platform with stainless steel railings, including covering with carpet in standard colour (2 x 2 m, height 1 m)				
7861		Without side facing	each	2,812.10
7866		Side facing molleton (standard colour)	each	3,557.30
7867		Side facing synthetic material white	each	3,060.50
7868		Side facing mono-colour painted (standard colour)	each	3,308.90
7869		Higher than 1 m up to max. 2 m	per 20 cm	380.40
		Other colours and sizes on request subject to surcharge		
Platform type B: stairs and platform with steel railings, black, including covering with carpet in standard colour (2 x 2 m, height 1 m)				
7874		Without side facing	each	1,489.40
7876		Side facing molleton (standard colour)	each	2,233.50
7877		Side facing synthetic material white (standard colour)	each	1,736.70
7878		Side facing mono-colour painted (standard colour)	each	1,985.10
7879		Higher than 1 m up to max. 2 m	per 20 cm	297.90
		Other colours and sizes on request subject to surcharge		

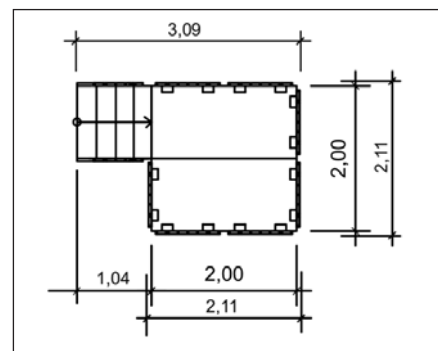

- Keep clear a minimum space of 1m x 1m in front of the stairs.
- Platforms may only be installed on the hall floor. Should a raised floor be laid around the platform, make sure that all steps have the same height in the finished state. Should the customer request the stairs to be installed on a platform, appropriate load distribution must be ensured and if need be structural certification must be submitted.
- Exhibitors shall protect any transits to, and areas between, exhibits against falls from a height.
- Areas below platforms must not be used, not even for material storage purposes.
- A technical inspection of the platforms is included in the price. Additional inspections for other stand structures must be registered and paid for by exhibitors.

We hereby order the following services **for hire** in accordance with the Conditions of Participation and Technical Guidelines.

2/2 >>

Name of the company
Street
Postal code and place
Country

Contact
Telephone
Telefax
Email

Company Stamp, date, signature

Stairs and Platforms

To be ordered via form B 10

Order Form

Trade Fair Stand

B
10

Platform type A – the standard colours of the carpet are: black, grey, green, blue, red



7861

Platform type A:
stairs and platform with stainless steel railings, including covering with carpet in standard colour without side facing



7866

Platform type A:
stairs and platform with stainless steel railings, including covering with carpet in standard colour side facing molleton (standard colour – white or black)



7867

Platform type A:
stairs and platform with stainless steel railings, including covering with carpet in standard colour side facing synthetic material white



7868

Platform type A:
stairs and platform with stainless steel railings, including covering with carpet in standard colour side facing mono-colour painted (standard colour – white or black)



7869

Platform type A:
stairs and platform with stainless steel railings, including covering with carpet in standard colour higher than 1m up to max. 2m

Platform type B – the standard colours of the carpet are: black, grey, green, blue, red



7874

Platform type B:
stairs and platform with steel railings, black, including covering with carpet in standard colour without side facing



7876

Platform type B:
stairs and platform with steel railings, black, including covering with carpet in standard colour side facing molleton (standard colour – white or black)



7877

Platform type B:
stairs and platform with steel railings, black, including covering with carpet in standard colour side facing synthetic material white



7878

Platform type B:
stairs and platform with steel railings, black, including covering with carpet in standard colour side facing mono-colour painted (standard colour – white or black)



7879

Platform type B:
stairs and platform with steel railings, black, including covering with carpet in standard colour higher than 1m up to max. 2m



Messe
Düsseldorf

Fax +49 211 4560-8566

Messe Düsseldorf GmbH, Abt.: UT-SAS
Postfach 10 10 06, 40001 Düsseldorf, Germany

Phone +49 211 4560-500
tr-service@messe-duesseldorf.de

Questions?

Order Form

Stand Walls/Paper Hanging

You will find further information at section 4.7.6 of the Technical Guidelines

Please enter orders in the ground plan sketch sent to you with the approval documentation (can also be called up and processed in OOS online in the forms for technical performance items). Prices include material (rental), construction and dismantling.

For incomplete documentations and all orders submitted less than 21 days before set-up time Messe Düsseldorf adds a surcharge of 35% on the fees.

Event
Hall/Stand number

B 11
GB
2026

Trade Fair Stand

B
11

Ident-Nr.	Amount ordered	The length of all stand construction dimensions must be divisible by 0.5!	Unit	Rental price per unit in € plus VAT
1. Standard elements Plastic surface, height 2.50 m*				
1111		Metres of wall element, 1.00 m wide	m	42.90
1112		Wall elements, 1.00 m wide, with fitted locking room door	Each	158.80
1114		Metres of panel, 0.5 m high	m	53.00
1123		Metres of panel, 0.30 m high	m	51.70
1120		Wall elements, 1.00 m wide, with fitted folding door	Each	143.10
2. Standard elements Type WKM 300 Brown hardboard surface, height 3.00 m				
1501		Metres of wall element, brown hardboard, 1.00 m wide	m	91.90
1504		Wall elements, brown hardboard, 1.00 m wide, with fitted locking room door	Each	171.90
These special elements are suitable for nailing and covering with fabric. See attachment for technical details				
3. Paperhanging and painting (please tick as appropriate)				
2101		Woodchip paper (antique white)	m ²	12.20
	<input type="checkbox"/> tick box	Standard elements, plastic surface		
	<input type="checkbox"/> tick box	Special elements Type WKM 300, brown hardboard surface		
2102		Woodchip paper with white paint	m ²	24.10
	<input type="checkbox"/> tick box	Standard elements, plastic surface		
	<input type="checkbox"/> tick box	Special elements Type WKM 300, brown hardboard surface		
2107		Woodchip paper with colour paint	m ²	27.80
	<input type="checkbox"/> tick box	Standard elements, plastic surface		
	<input type="checkbox"/> tick box	Special elements Type WKM 300, brown hardboard surface		

(Colour specification e.g., RAL/NCS)

(Please attach colour sample)

We shall carry out the erection work ourselves. Your contact at our office:

Name:
Tel.

We have commissioned the following contractor with the erection

Company:
Street:
Town:

* The standard elements (Ident.-No. 1111 – 1120) offered here serve stand delimitation purposes and are not suited for stand design. Should you wish to use them nevertheless, woodchip wallpapering (No. 2101 / 2102 / 2107) is highly recommended.

Contact/Project manager:

Name:
Tel.
Fax

We hereby order the following services **for hire** in accordance with the Conditions of Participation and Technical Guidelines.

2/2 >>

Name of the company
Street
Postal code and place
Country

Contact
+ Telephone
+ Telefax
Email

Company Stamp, date, signature

Stand Construction Units Available on Hire (order via Form "Stand Walls/Paper Hanging")

1. Standard-Construction Unit

Surface plastic, height 2.50 m

Order Form

B 11
GB

2026

All the individual units available are as briefly described. The units constitute a shell construction system, affording considerable latitude for stand construction to suit individual requirements.

We recommend that a surface finish (e.g. wood chip paper) be applied to the partitions: Following papering, the partitions may only be painted with a distemper or emulsion paint.

It is imperative to ensure that the construction units are not damaged in any way by fasteners or fixings for display materials or exhibits.

Attention is also drawn to the Technical Directives and to the information and instructions contained therein.

Please observe to the following stand construction regulations:

- Free-standing wall lengths exceeding 5 m must be stabilized with a supporting wall
- All free-standing stands must be assembled in the shape of an angle, a U, an X or zigzag.

- ① **Partition unit**
1000 mm x 2500 mm 40 mm thick, with an upper and a lower aluminium rail for attaching special plastic injection mouldings, for mounting light fittings, perforated rails for wall shelves and decorations. The partition unit consists of a wooden frame, faced on both sides with 2,5 mm thick hard fibreboard, with a melamine resin finish.
- ② **Wandelement**
500/2500 mm, otherwise as per (1).
- ③ **Door unit/folding door**
1000 mm x 2500 mm, 40 mm thick, with lockable flush door, right or lefthand hung, giving a clear opening of 820 mm x 2000 mm, with a top and bottom aluminium trim and a flat iron bottom rail.
- ④ **Fascia element**
1000 mm x 500 mm, 40 mm thick, with two aluminium trims, also with curtain rail including a light grey fabric curtain.
- ⑤ **Aluminium support**
2500 long, 40 mm square, 40 mm square, to support headers over corner entrance or header units exceeding 4 metres in enight.

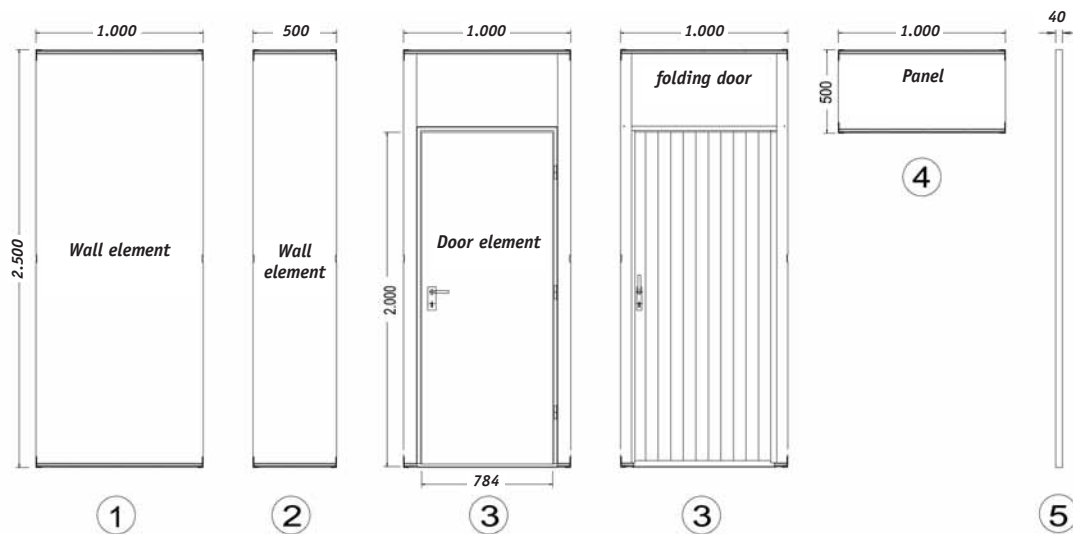

2. Special Construction Elements Type WKM 300

Brown hardboard surface, height 3.00 m

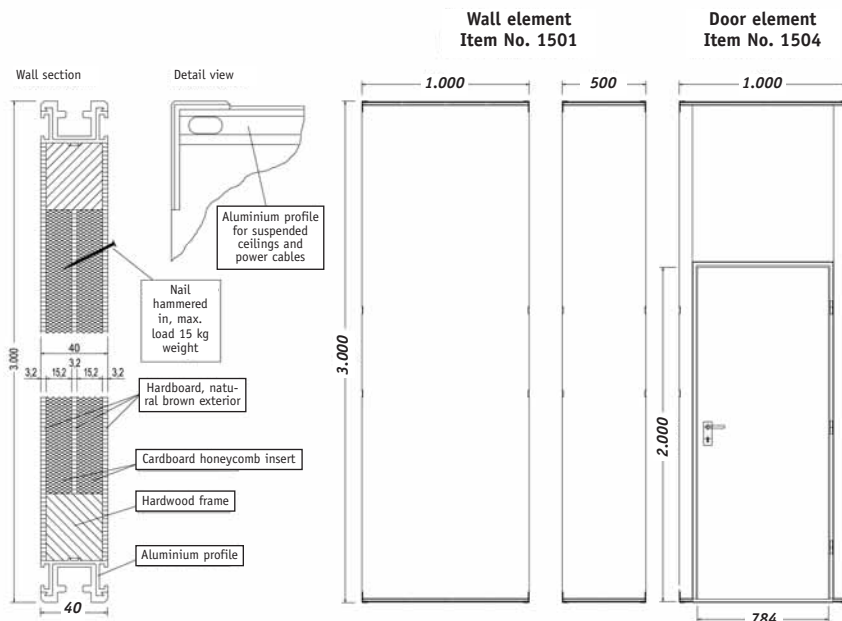

Messe Düsseldorf – Wall construction system Type 300

Technical note on stand construction

The stand walls have a central hardboard of 3.2 mm thickness with hardboard of 4 mm thickness on both sides.

Special features

Some regulations must be observed before applying nails to the walls:

- Nails up to 15 mm length are adequate for small exhibits up to 2 kg per suspension point.
- Nails of at least 25 mm, maximum 35 mm length must be used for exhibits weighing more than 2 kg per suspension point. The minimum nail diameter must be 2.5 mm. The permitted maximum weight per suspension point is 15 kg.
- After penetrating the outer hardboard, the nail must be hammered into the central board.

Please observe to the following stand construction regulations:

- Free-standing wall lengths exceeding 5 m must be stabilized with a supporting wall
- All free-standing stands must be assembled in the shape of an angle, a U, an X or zigzag.

Please fax or send

Questions?

Order Form

B 12
GB
2026



Fax +49 211 4560-8566
 Messe Düsseldorf GmbH, Abt.: UT-SAS
 Postfach 10 10 06, 40001 Düsseldorf, Germany
 Phone +49 211 4560-500
 tr-service@messe-duesseldorf.de

Clearance of Special Structures

You will find further information at section 4.2.1, 4.9.1 of the Technical Guidelines

Event
Hall/Stand number

We are planning the erection

- of a multi-storey stand
- of a pedestal design over 20 cm in height
- of the following special stand superstructure

and request clearance for this construction project following checking by an engineer for construction statics.

Trade fair construction company

Firm _____

Address _____

Officer in charge _____

Tel.: _____ Fax: _____

Email: _____

The "Technical Guidelines" are to be observed and represent a component of taking part in the trade fair. Meaningful documents such as groundplan, view and cross-section drawings, construction and operating descriptions, **checkable static proofs** and construction drawings must have been received by Messe Düsseldorf not later than 6 weeks prior to commencement of the erection period. These documents must be submitted **in the German language**. For documents submitted belatedly a surcharge will be charged. The final report on the inspection, supervision and acceptance of the verified stand construction(s) may be provided either on paper or by email, at Messe Düsseldorf's discretion.

Planner of supporting structure

Firm _____

Address _____

Officer in charge _____

Tel.: _____ Fax: _____

Email: _____

Ident-Nr.	Checking/inspection charge for documents completely submitted up to 6 weeks prior to commencement of the construction period:	Unit	Price per Unit € plus VAT
3104	Pedestals higher than 20 cm and other special structures	Each	475.60
3110	Two-storey form of construction up to 200 m ²	Each	1,263.70
3112	Two-storey form of construction over 200 m ²	Each	1,581.50
Ident-Nr.	Checking/inspection charge for documents completely submitted up to 14 days prior to commencement of the construction period:	Unit	Price per Unit € plus VAT
3106	Pedestals higher than 20 cm and other special structures	Each	964.60
3114	Two-storey form of construction up to 200 m ²	Each	1,696.40
3115	Two-storey form of construction over 200 m ²	Each	2,169.40
Ident-Nr.	Checking/inspection charge for documents completely submitted 14 days or less prior to commencement of the construction period:	Unit	Price per Unit € plus VAT
3107	Pedestals higher than 20 cm and other special structures	Each	1,320.70
3120	Two-storey form of construction up to 200 m ²	Each	2,820.40
3121	Two-storey form of construction over 200 m ²	Each	3,353.40
3100	Extra efforts involved in the inspection / approval of special structures, pedestals, two-storey exhibition stands (in addition to the usual inspection fee)	Hour	231.80

Clarification on the checking and clearance processes for multi-storey trade fair stand as well as special superstructures and devices on stands. In order to ensure the safety to traffic on the trade fair grounds, the construction and operation of multi-storey trade fair stands as well as of special superstructures and devices on stands as described in more detail under Para 4.2.1 of the Technical Guidelines can only be approved following checking, construction supervision and acceptance by an engineer for construction statics appointed by the Messe management. Charges for checks shall be borne in every case by the exhibitor. The basis for all stand structures is the NW construction order in its particular valid version. In the case of the erection of temporary structures within the meaning of Section 79 BauO NRW – Temporary Structures, their acceptance for use must also be carried out by the Building Inspectorate of the City of Düsseldorf. The resulting fees will be invoiced by Messe Düsseldorf in addition to the inspection fee.

We hereby order the following services **for hire** in accordance with the Conditions of Participation and Technical Guidelines.

Name of the company _____

Street _____

Postal code and place _____

Country _____

Contact _____

Telephone _____

Telefax _____

Email _____

 Company Stamp, date, signature



Messe Düsseldorf

Fax +49 211 4560-8566

Messe Düsseldorf GmbH, Abt.: UT-SAS
Postfach 10 10 06, 40001 Düsseldorf, Germany

Phone +49 211 4560-500
tr-service@messe-duesseldorf.de

Questions?

Suspension orders (page 2) are only accepted when submitted with this information!

Order Form

Suspension

Event
Hall/Stand number

Trade Fair Stand

B 21 GB

2026

B 21

We plan to order suspensions for mounting

- 1) Lightweight decoration elements (flags, banners and the like)
- 2) Media equipment (loudspeakers, video projectors and the like)
- 3) Rigs (aluminium trusses etc. for mounting spotlights and other equipment)
- 4) Wooden structures (fascias, ceilings made of wood or other materials, etc.)
- 5) Other (recessed Downlights, transformers etc.): _____

Total weight of the structure to be suspended _____ kg

Do you have static load calculations that you could submit? Yes No

Please attach detailed plans! (Dimensions, loads and the exact position of the stand area must be clearly stated.)

We intend to assemble using (not an order):

- Hydraulic Lift
- Manual Chain Hoists *)
- Electric Chain Hoists *)

Planned quantity: _____ pcs.

*) Installations using manual and/or electric chain hoists cannot be performed without static load calculations and load plans. Dead weights, dynamic factors and uneven loads applied to suspension points that may result from hoisting operations shall be taken into consideration. Chain hoists must not be attached to wire ropes and/or lattice beams of Messe Düsseldorf!

Scheduled installation date: _____

Executing company / Contact person:

Person in charge: _____

Mobile phone: _____

Company: _____

Address: _____

Phone: _____ Fax: _____

E-Mail: _____

- We ask for a quote and execution by Messe Düsseldorf (subject to a charge). The submission of a sketch is mandatory for an offer.

2/2 >>

<p>Name of the company _____</p> <p>Street _____</p> <p>Postal code and place _____</p> <p>Country _____</p>	<p>Contact _____</p> <p>+ Telephone _____</p> <p>+ Telefax _____</p> <p>Email _____</p> <p>_____</p> <p>Company Stamp, date, signature</p>
--	--



Messe
Düsseldorf

Fax +49 211 4560-8566

Messe Düsseldorf GmbH, Abt.: UT-SAS
Postfach 10 10 06, 40001 Düsseldorf, Germany

Phone +49 211 4560-500
tr-service@messe-duesseldorf.de

Questions?

Order Form

Suspension Structures

You will find further information at section 4.7.5 of the Technical Guidelines

Please enter orders in the ground plan sketch sent to you with the approval documentation (can also be called up and processed in OOS online in the forms for technical performance items). Prices include material (rental), construction and dismantling.



For incomplete documentations and all orders submitted less than 21 days before set-up time Messe Düsseldorf adds a surcharge of 35% on the fees.

Event
Hall/Stand number

B 21
GB
2026

Trade Fair Stand

B
21

Ident-Nr.	Amount ordered	Max. load 50 kg per ceiling intersection	Unit	Rental price per unit in € plus VAT
		Halls 3 – 5, 9 – 14		
1302		Suspension installations with ring attachment and 1 wire rope, 4 mm in diameter	Each	128.80
1304		Suspension installations with ring attachments, 39 mm in diameter at a height of 8 m	Each	96.40
1305		Additional wire rope(s), dia. 4 mm , on suspension installations	Each	32.40
1307		2-point grid support at 8 m height for suspending items beyond the ceiling nodes (the suspension devices must always be ordered for this)	m	31.70
1323		Wire-rope suspension installations dia. 4-mm , on assembled 2-point truss support (order no. 1307)	Each	32.40
		Hall 6		
1316		Suspension installations with ring attachment and 1 wire rope, 4 mm in diameter	Each	185.10
1318		Suspension installations with ring attachment, 39 mm in diameter at a height of 14 or 26 m	Each	152.70
1305		Additional wire rope(s), dia. 4 mm , on suspension installations	Each	32.40
1307		2-point grid support at 8 m height for suspending items beyond the ceiling nodes (the suspension devices must always be ordered for this)	m	31.70
1323		Wire-rope suspension installations dia. 4-mm , on assembled 2-point truss support (order no. 1307)	Each	32.40
		Halls 1, 7a, 8a, 8b		
1328		Suspension installations with ring attachment and 1 wire rope, 4 mm in diameter	Each	131.00
1330		Suspension installations with ring attachments, 39 mm in diameter at a height of 12 or 14 m	Each	98.60
1305		Additional wire rope(s), dia. 4 mm , on suspension installations	Each	32.40
1307		2-point grid support at 8 m height for suspending items beyond the ceiling nodes (the suspension devices must always be ordered for this)	m	31.70
1323		Wire-rope suspension installations dia. 4-mm , on assembled 2-point truss support (order no. 1307)	Each	32.40
		Halls 15 – 17 on inquiry		
1352		Suspension installations with ring attachment and 1 wire rope, 4 mm in diameter	Each	130.90
1305		Additional wire rope(s), dia. 4 mm , on suspension installations	Each	32.40
1307		2-point grid support at 8 m height for suspending items beyond the ceiling nodes (the suspension devices must always be ordered for this)	m	31.70
1323		Wire-rope suspension installations dia. 4-mm , on assembled 2-point truss support (order no. 1307)	Each	32.40
		Accessories		
1309		 Hook-and-eye coupling for wire cables with a diameter between 4 and 5 mm . (Only approved hook-and-eye couplings in accordance with DIN may be used)	Price Each	19.20
1310		 Type 50 S wire holder with ring nut for wire cables, dia. between 4 and 5 mm	Price Each	30.50

We hereby order the following services **for hire** in accordance with the Conditions of Participation and Technical Guidelines.

Name of the company
Street
Postal code and place
Country

Contact
+ Telephone
+ Telefax
Email

Company Stamp, date, signature



Messe
Düsseldorf

Fax +49 211 4560-8566

Messe Düsseldorf GmbH, Abt.: UT-SAS
Postfach 10 10 06, 40001 Düsseldorf, Germany

Phone +49 211 4560-500
tr-service@messe-duesseldorf.de

Electric Stand Installations – Halls –

You will find further information at section 3.1.1, 3.1.2, 5.3 of the Technical Guidelines

Please enter orders in the ground plan sketch sent to you with the approval documentation (can also be called up and processed in OOS online in the forms for technical performance items), otherwise entry as Messe Düsseldorf sees fit. Prices include material (rental), construction and dismantling. For outdoor area see Form „Electrical Installations/Sanitary Installations – Open-air Area –“. For incomplete documentations and all orders submitted less than 21 days before set-up time Messe Düsseldorf adds a surcharge of 35% on the fees.

Event
Hall/Stand number

Ident-Nr.	Amount ordered	Electrical Installations	Unit	Rental price per unit in € plus VAT
Electrical packages				
2200		Power connection up to 3.3 kW incl. 1 Euro power socket 230 V, 10 A, 2.3 kW and 1 fridge power socket 230 V, 4 A, up to 0.9 kW, 24-hour operation	Each	198.70
2201		Power connection up to 2.3 kW, incl. 1 Euro power socket 230 V, 10 A, up to 2.3 kW	Each	153.20
2195		Power connection up to 7 kW incl. 2 Euro power socket 230 V, 10 A, 2.3 kW and 1 fridge power socket 230 V, 4 A, up to 0.9 kW, 24-hour operation	Each	327.10
Main power connections (additional installations required):				
2202		3-phase current connections, 400 V up to 7 kW	Each	189.90
2203		3-phase current connections, 400 V up to 14 kW	Each	292.90
2204		3-phase current connections, 400 V up to 19 kW	Each	351.40
2205		3-phase current connections, 400 V up to 24 kW	Each	485.40
2206		3-phase current connections, 400 V up to 34 kW	Each	588.40
Additional installations (only in conjunction with main power connections 2202-2206, without electrical packages!)				
Power sockets:				
2241		Euro power socket 230 V, 10 A, up to 2.3 kW (can be switched off)	Each	46.30
2237		Euro power socket 230 V, 10 A, up to 2.3 kW (cannot be switched off, 24-hour operation)	Each	46.30
2240		Fridge power socket 230 V, 4 A, up to 0.9 kW (cannot be switched off, 24-hour operation)	Each	46.30
CEE sockets:				
2243		CEE sockets, (red), 3-pole + N + E, 400 V, 16 A (for Id. 2202)	Each	89.00
2256		CEE sockets, (red), 3-pole + N + E, 400 V, 32 A (for Id. 2204)	Each	146.90
2255		CEE sockets, (red), 3-pole + N + E, 400 V, 63 A (for Id. 2206)	Each	193.70
2242		CEE sockets, (blue) 1-pole, 230 V, 16 A, 10 amps fused, up to 3.3 kW	Each	64.90
Miscellaneous:				
2248		Wieland coupler 230 V, 10A up to approx. 2.3 kW for exhibitor's own lighting fixtures	Each	51.50
2251		earthing connection for earthing the stand, required for metal stands	Each	43.50
2252		Two round pin socket 230 V up to 2,3 KW, fed in from power distributor at the stand and laid via hall ceiling, only available in halls 3-5 and 9-14	Each	338.70
2262		16 A CEE couplers 400 V, fed in from power distributor at the stand and laid via hall ceiling, all halls (except Hall 6)	Each	607.60
2298		16 A CEE couplers 400 V, with adaptation to 3 Euro power sockets, fed in from power distributor at the stand and laid via hall ceiling – all halls (except hall 6)	Each	682.10
2990	<input type="checkbox"/> tick box	Underground laying of cables. Price including reinstatement of floor	m	322.90
2268	<input type="checkbox"/> tick box	General technical hall services (electric)	hour	91.90
Main connections (direct without distribution boxes):				
2207		3-phase current connections, 400 V up to 45 kW	Each	658.80
2208		3-phase current connections, 400 V up to 60 kW	Each	913.90
2209		3-phase current connections, 400 V up to 80 kW	Each	1,480.10

The current price of electricity is kW/h € 0.74 plus VAT. The current consumption will be determined by metering. For connecting the stand to the electric mains in the hall, a basic fee of € 31.50 will be charged.

For safety reasons, the electric power will be switched off one hour after closure of the event on the last day. Cable lengths for all AC and three-phase current connections from the floor outlet stand at approx. 5 m. Excess lengths available on demand.

We hereby order the following services for hire in accordance with the Conditions of Participation and Technical Guidelines.

Name of the company
Street
Postal code and place
Country

Contact
+ Telephone
+ Telefax
Email

Company Stamp, date, signature



Messe
Düsseldorf

Fax +49 211 4560-8566

Messe Düsseldorf GmbH, Abt.: UT-SAS
Postfach 10 10 06, 40001 Düsseldorf, Germany

Phone +49 211 4560-500
tr-service@messe-duesseldorf.de

Electrical Installations of Machines/Exhibits – Halls –

You will find further information at section 3.1.1, 3.1.2, 5.3 of the Technical Guidelines

Please enter orders in the ground plan sketch sent to you with the approval documentation (can also be called up and processed in OOS online in the forms for technical performance items), otherwise entry as Messe Düsseldorf sees fit. Prices include material (rental), construction and dismantling. For outdoor area see Form „Electrical Installations/Sanitary Installations – Open-air Area –“. For incomplete documentations and all orders submitted less than 21 days before set-up time Messe Düsseldorf adds a surcharge of 35% on the fees.

Event
Hall/Stand number

Ident-Nr.	Amount ordered	Electrical Installations	Unit	Rental price per unit in € plus VAT
-----------	----------------	--------------------------	------	-------------------------------------

Main power connections

2201		AC power supply 230 V 1-PH up to 2.3 kW	Each	153.20
2202		3-phase current connections, 400 V 3-PH up to 7 kW	Each	189.90
2203		3-phase current connections, 400 V 3-PH up to 14 kW	Each	292.90
2204		3-phase current connections, 400 V 3-PH up to 19 kW	Each	351.40
2205		3-phase current connections, 400 V 3-PH up to 24 kW	Each	485.40
2206		3-phase current connections, 400 V 3-PH up to 34 kW	Each	588.40
2207		3-phase current connections, 400 V 3-PH up to 45 kW	Each	658.80
2208		3-phase current connections, 400 V 3-PH up to 60 kW	Each	913.90
2209		3-phase current connections, 400 V 3-PH up to 80 kW	Each	1,480.10
2210		3-phase current connections, 400 V 3-PH up to 100 kW	Each	1,974.80
2211		3-phase current connections, 400 V 3-PH up to 120 kW	Each	2,265.60
2212		3-phase current connections, 400 V 3-PH up to 150 kW	Each	3,024.30
2213		3-phase current connections, 400 V 3-PH up to 200 kW	Each	4,078.90

Prices for connections over 200 kW upon request. All power connections are subject to a capacity factor of $\text{COS}\varphi = 0.8$ and a frequency of 50 Hz. Cable lengths for all connections are approx. 5 m from floor outlets. Excess lengths over 5 m available on request, against a surcharge.

We need the following connections without ELCB switches: _____

According to VDE 0100 Part 711, an ELCB switch (RCD) with less than 30 mA cut-off current is mandatory for power terminal circuits such as socket outlets and light feed-in up to 32 ampère.

CEE couplers (up to 32 A only in connection with ELCB switch (RCD) less than 30 mA cut-off current)

2242		CEE sockets, (blue) 1-pole, 230 V, 16 A, 10 amps fused, up to 3.3 kW – to order with RCD 30mA only	Each	64.90
2243		CEE sockets, (red), 3-pole + N + E, 400 V, 16 A, up to 10,0 kW – to order with RCD 30mA only	Each	89.00
2256		CEE sockets, (red), 3-pole + N + E, 400 V, 32 A, up to 20,0 kW – to order with RCD 30mA only	Each	146.90
2255		CEE sockets, (red), 3-pole + N + E, 400 V, 63 A up to 39,0 kW	Each	193.70
2245		CEE sockets, (red), 3-pole + N + E, 400 V, 125 A up to 60,0 kW	Each	274.30

Direct connections (only in conjunction with main power connections ID 2201 – 2213):

2157		Connecting of a machine or sub-distribution up to 60 kW	Each	241.70
2158		Connecting of a machine or sub-distribution up to 80 – 200 kW	Each	378.30

Miscellaneous:

2251		earthing connection for earthing the stand, required for metal stands	Each	43.50
2990	<input type="checkbox"/> tick box	Underground laying of cables. Price including reinstatement of floor	m	322.90

The current price of electricity is kW/h € 0.74 plus VAT. The current consumption will be determined by metering. For connecting the stand to the electric mains in the hall, a basic fee of € 31.50 will be charged. For safety reasons, the electric power will be switched off one hour after closure of the event on the last day. A power factor of $\text{COS}\varphi = 0.8$ applies to all power connections.

We hereby order the following services for hire in accordance with the Conditions of Participation and Technical Guidelines.

Name of the company	Contact
Street	+ Telephone
Postal code and place	+ Telefax
Country	Email
VAT ID	Company Stamp, date, signature

Sanitary Installations/Compressed Air

You will find further information at section 3.1.2, 3.2.2, 5.4, 5.5, 5.6.3 of the Technical Guidelines

Please enter orders in the ground plan sketch sent to you with the approval documentation (can also be called up and processed in OOS online in the forms for technical performance items), otherwise entry as Messe Düsseldorf sees fit. Prices include material (rental), construction and dismantling. For outdoor area see Form „Electrical Installations/Sanitary Installations – Open-air Area –“. **For incomplete documentations and all orders submitted less than 21 days before set-up time Messe Düsseldorf adds a surcharge of 35% on the fees.**

Event
Hall/Stand number

Ident-Nr.	Amount ordered	Sanitary Installations/Compressed Air	Unit	Rental price per unit in € plus VAT
2300		Water supply connection to kitchen, incl. connection of an exhibitor's own sink and water consumption	Each	700.70
2301		Water connections with 1/2" supply (DN 15) – 2" discharge (DN 50) ^{*1)}	Each	595.10
2302		Water connections with 1" supply (DN 25) – 2" discharge (DN 50) ^{*2)}	Each	929.40
2315		Connection to exhibitor's own wash basins and sinks	Each	105.60
2316		Connection to exhibitor-owned equipment (e.g.. connection of dishwashers)	Each	141.80
2317		connect exhibitor's own hot water heaters and/or coffee percolators (without discharge)	Each	71.40
2990	<input type="checkbox"/> tick box	Underground laying of pipes within the stand Price including reinstatement of floor	m	322.90
2311		additional pipe laying supply up to 3/4" to the upper floor	running metres	37.60
2312		additional pipe laying discharge up to 2" to the upper floor	running metres	53.50

*1) Water use incl. wastewater per m³ € 5.50.

*2) Consumption is charged as flat rate.

The water pressure is 2.0 to max. 5.0 bar with sufficient dimensioning, with a promised flow pressure of 1 bar for stand supply. For minimum pressure and quantity requirements, please contact MESSE DÜSSELDORF. For safety reasons, the water supply will be cut off one hour after closure of the event on the last day. The drinking water temperature varies between 10 - 20°C depending on the season and weather.

3200		Compressed air connection 1/4" , for up to 300 l/min	Each	499.90
3201		Compressed air connection 1/2" , for up to 700 l/min	Each	789.70
3202		Compressed air connection 3/4" , for up to 1400 l/min	Each	1,178.90
3203		Compressed air connection 1" , for up to 2300 l/min	Each	1,837.10
3204		Compressed air connection 1 1/4" , for up to 4000 l/min	Each	2,913.50
2990	<input type="checkbox"/> tick box	Underground laying of pipelines within the stand area Price including reinstatement of floor	m	322.90

The pressure available from Messe Düsseldorf amounts to max. 7.85 bar.

If lower pressure is required, pressure reducers must be provided by the exhibitor.

Air consumption is included in the price.

For safety reasons, the compressed air supply will be cut off one hour after closure of the event on the last day.

Our total capacity during continuous use will amount to l/min. air intake.

According to § 5.6.3 of the Technical Regulations, we will install a pressure vessel with a test pressure of bar and a volume of l

We hereby order the following services **for hire** in accordance with the Conditions of Participation and Technical Guidelines.

Name of the company
Street
Postal code and place
Country

Contact
+ <input type="text"/>
Telephone
+ <input type="text"/>
Telefax
Email



Stand Lighting

You will find further information at section 5.3.2 of the Technical Guideline

Please enter orders in the ground plan sketch sent to you with the approval documentation (can also be called up and processed in OOS online in the forms for technical performance items). Prices include material (rental), construction and dismantling.

For incomplete documentations and all orders submitted less than 21 days before set-up time Messe Düsseldorf adds a surcharge of 35% on the fees.

Event
Hall/Stand number

Lighting from the ceiling

Ident-Nr.	Amount ordered	Stand lighting	Unit	Rental price per unit in € plus VAT
2188		High-performance spotlight HQI 400, 230 V, halls 1-5 and 9-14 from the hall ceiling, *) Halls 3-5 and 9-14 mounted on lower edge = at a height of approx. 8m (surface illumination of approx. 5x5m)	Each	387.10
2186		Shark luminaire, Hall 7.0, metal halide luminaire 70 W, 230 volt warm white, on 3-phase busbar with flexible rotation and tilting, infinitely adjustable beam angle (15°-40°)	Each	78.70
Please note:		In Halls 1, 6, 7a, 8a, 8b and 15 - 17 we cannot offer you illumination that comes exclusively from the ceiling, due to the height of the hall. However, we would be pleased to give you a customised proposal, using lighting trusses. Give us a ring: +49 211 4560-500 or send us an email: TR-Service@messe-duesseldorf.de.		

*) All electrical supplies lines for lighting required to be suspended from the ceiling are supplied with current from the electrical connection at the stand.

Lighting at the stand

Ident-Nr.	Amount ordered	Stand lighting	Unit	Rental price per unit in € plus VAT
2246		Light fitting including bulb 100 W	Each	67.30
2249		Light fitting with cantilever arm including bulb 100 W	Each	74.70
2281		Spotlight, 100 W, on supply track	Each	80.40
2282		Halogen spotlight, 300 W, on supply track	Each	127.80
2288		Halogen spotlight, white, 150 W with 90 cm cantilever arm	Each	92.60
2289		Halogen spotlight, white, 150 W (additional spotlight for item no. 2288) on cantilever arm	Each	53.80
2290		Baby-Star spotlight, white, 100 W with 90 cm cantilever arm	Each	80.60
2292		Baby-Star spotlight 100 W, white, (additional spotlight for item no. 2290) on cantilever arm	Each	46.60

These installations require you to order an AC and/or three-phase current connection (adapt kW data to these orders) using the order form "Electrical Installation Hall".

It is not always possible to install luminaires to the exhibitor's own material, feasibility is checked on site.

IDs 2246, 2249, 2288 and 2289 can only be mounted to Messe Düsseldorf wall elements (form B 11)!

On the last day of the trade fair the electricity supply will be cut off one hour after the end of the event for safety reasons.

We hereby order the following services **for hire** in accordance with the Conditions of Participation and Technical Guidelines.

2/2 >>

Name of the company
Street
Postal code and place
Country

Contact
Telephone
Telefax
Email

Stand Lighting

To be ordered via form B 25

Order Form

B 25
GB

2026

Trade Fair Stand

B
25

Lighting from the ceiling



2188

High-performance spotlight HQ1
400 W, 230 volt, Halls 1-5, 9-14
from the hall ceiling, length 40 cm,
width 33 cm, height 28 cm



2186

Shark luminaire, Hall 7.0,
Metal halide steam jet luminaire
70 W, 230 Volt warm white on
3-phase, busbar, focusable

Lighting at the stand



2246

Light fitting including bulb
100 W



2249

Light fitting with spotlight
and bulb, bracket, length 50 cm,
100 W



2281

Spotlight, 100 W
on busbar



2282

Halogen spotlight, 300 W
on busbar



2288

Halogen spotlight 150 W, white
with bracket, length 90 cm
on busbar



2289

Halogen spotlight, 150 W, white
(additional spotlight for use with 2288)
on busbar



2290 + 2292

Baby Star spotlight 100 W, white
with bracket, length 90 cm
on busbar



Anchoring in the Hall Floor

You will find further information at section 4.7.3 and 4.7.4 of the Technical Guidelines

Event
Hall/Stand number

Ident no.	Registered amount	Service	Unit	Price per drill in € plus VAT
2408		Anchoring in the hall floor	Drill hole	80.00

Provisions on anchoring exhibits to the floor.

- The affixing (securing) of machinery and other building components using floor anchors is only possible with written consent from Messe Düsseldorf. Please attach to this form plans drawn to scale with information on the position and the diameter of the drill holes as well as the number of drill holes required. The number of anchors must be restricted to the smallest-possible amount. The number of drill holes allowed by Messe Düsseldorf must be absolutely adhered to.
- Drill holes must be at least 25 cm away from supply and access channels (a site plan identifying the supply channels is available in the Online Order System (OOS) or in the stand construction portal), maximum drill hole depth is 280 mm from the floor surface (mastic asphalt layer is about 25 mm deep). Drill holes must be vertical.

3. The orderer is responsible for the work; the registered anchors are checked on site by the hall inspector in charge. Messe Düsseldorf must be notified immediately of any deviations or changes.

4. Closing or sealing of the drill holes after the event is done by Messe Düsseldorf.

Exhibitors will be charged an amount of € 135.00 per drill hole for each unregistered drill hole or in case of exceedance of the amount allowed by Messe Düsseldorf.

The permission to drill holes must be confirmed by Messe Düsseldorf and must not be taken for granted.

In the event of a violation of the provisions, Messe Düsseldorf reserves the right to use the deposit made by the exhibitor for technical services for the remedy of the damage caused to the building.

We hereby order the following services **for hire** in accordance with the Conditions of Participation and Technical Guidelines.

Name of the company
Street
Postal code and place
Country

Contact
Telephone
Telefax
Email

Company Stamp, date, signature

